

GLEITROHRSYSTEM GR 32/2 BAUFIX 200 (JP48279)

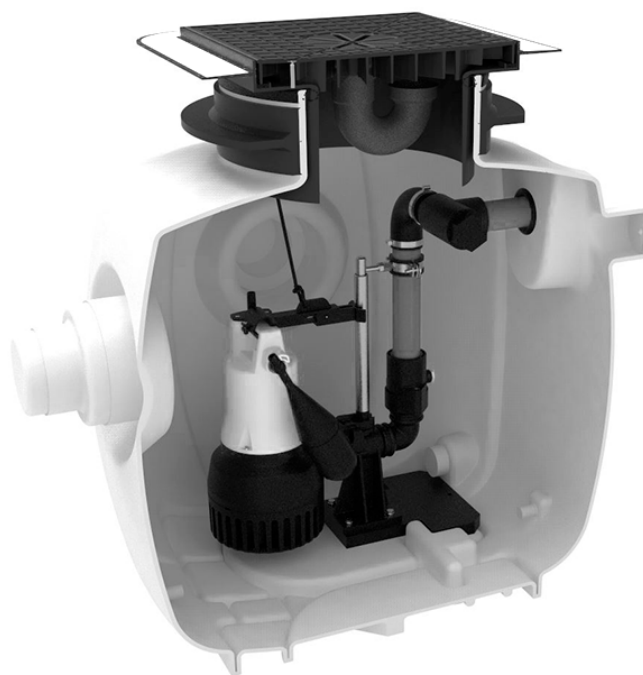

①



②

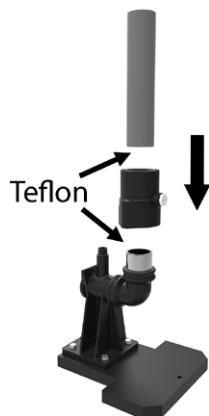

③



④



⑤



⑥



⑦

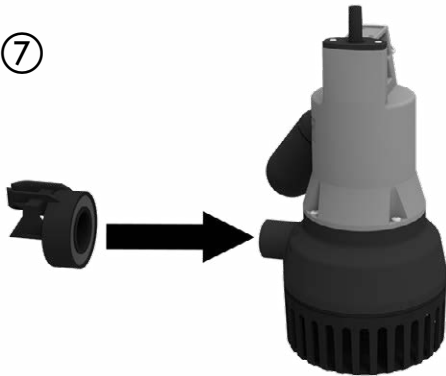

⑧

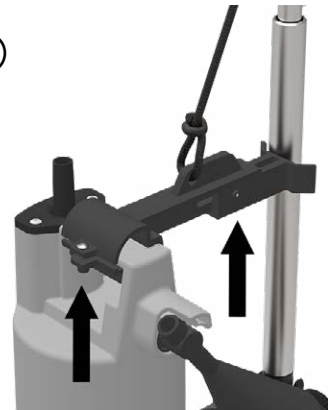

⑨

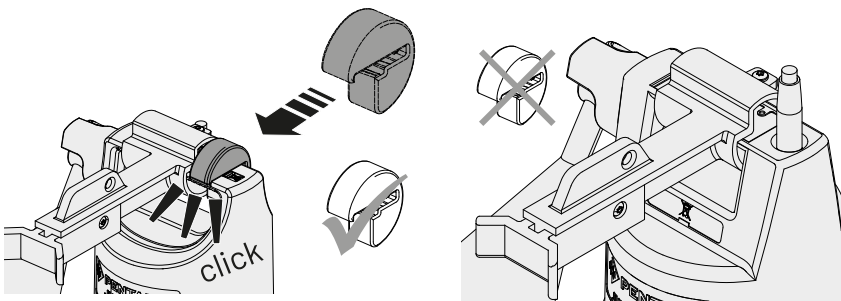

⑩



Jung Pumpen GmbH  
 Industriestr. 4-6  
 33803 Steinhagen  
 Deutschland  
 Tel. +49 5204 170  
 kd@jung-pumpen.de

Pentair Water Italy Srl  
 Via Masaccio, 13  
 56010 Lugnano - Pisa  
 Italia  
 Tel. +39 050 716 111  
 info@jung-pumpen.it

Pentair Water Polska Sp. z o.o.  
 ul. Plonów 21  
 41-200 Sosnowiec  
 Polska  
 Tel. +48 32 295 1200  
 infopl.jungpumpen@pentair.com

All indicated Pentair trademarks and logos are property of Pentair. Third party registered and unregistered trademarks and logos are the property of their respective owners.  
 © 2020 Pentair Jung Pumpen